

J1939 Vehicle Inertia Monitor

Advanced Vehicle Inertial Measurement and Vibration Monitoring Device

The J1939 Vehicle Inertia Monitor (VIM) formulates moving vehicle pitch and roll tilt estimates using multiple sensor fusion algorithms. It also performs advanced multi-rate frequency domain vibration processing using an onboard high speed Digital Signal Processor (DSP).

Unique in it's class : The Vehicle Inertia Monitor is not a typical digital inclinometer that is commonplace in the J1939 market. These common inclinometers are intended for static environments where the vehicle is not moving and therefore generate significant pitch / roll errors when the vehicle accelerates, decelerates or turns.

The VIM incorporates advanced signal processing techniques using dynamic modeling and detected vehicle motion from the SAE J1939 communication link. This results in extremely accurate pitch / roll estimates when the vehicle is in motion.

Additionally the VIM filters noise from these attitude estimates via sensor data fusion within a predictive Extended Kalman filter to provide fast, smooth data results in real-time.

Typical Applications:

- Real-Time Stabilized Vehicle Pitch / Roll Estimation for Moving HEV Power Tradeoff Control
- Road Roughness and Grade / Pitch Profiling
- Gearbox Vibration Monitoring and Trending for Preventative Maintenance Applications
- Autonomous Vehicle Terrain Classification



PRODUCT DATASHEET

VIM CAPABILITIES



- DSP Microcontroller Hosts Advanced Data Processing Algorithms and Applications
- J1939 CAN Bus Interface to Acquire and Transmit Vehicle Data used in Parameter Calculations
- Integrated MEMS Accelerometer and Gyroscope support Moving Vehicle Pitch and Roll Estimates
- Data Fusion via Advanced Kalman Filter with Vehicle Longitudinal / Lateral Acceleration Compensation
- 3 Axis 2-KHz Bandwidth Vibration Monitoring of 3 SubBand Frequency Grms-Force Levels with Real-Time Spectrum Transmission and Optional Order Tracking to a Configurable J1939 Parameter

SPECIFICATIONS

- **Power Requirements:**
7VDC to 36VDC Input Voltage Range ; 12VDC @ 1mA typ (Idle – Quiescent Sleep) ; 12VDC @ 22mA typ (Active – Streaming Data)
- **Digital Signal Processor (DSP):**
60MIPS ; 512Kx8 Pgm ; 48Kx8 Data
- **Non-Volatile Memory:**
1Mx8bit ; 20MHz Streaming Rate
- **MEMS Accelerometer:**
2000Hz BW ; +/-2, +/-6G Selectable ; 1.2mG / LSB Resol ; +/- 0.01% / DegC Sensitivity Change
- **MEMS Gyroscope:**
0.07Deg/s / LSB Resol ; 0.03 Deg/s / $\sqrt{\text{Hz}}$ RN Density ; +/- 0.016% / DegC Sensitivity Change ; On-Chip Die Temperature Sensor
- **J1939 PHY Interface:**
ISO-11898 Compliant, 250KBits/s Deep Sleep Capable ; Receptive State @ Power Loss ; Common Mode Filter - 1Kohm CMZ typ ; ESD Clamp to 40V @ 1A - 200W ; Optional 120ohm Termination (NonPop Std)
- **Connector:**
6 Contact ; Delphi Metri-Pack 150.2 Series 30u Gold Flash over Nickel Underplating
- **Maintenance:**
In-Field Firmware Upgrade Support via J1939 Prop-A2 PDU1
- **Environmental:**
-40 to +85 DegC ambient ; 0% to 100% RH Condensing ; Waterproof ; In-House Tested to IP-67
- **Enclosure:**
1.9"L x 2.3"W x 0.56"H ; Weight: 1.1 oz ; ABS Plastic w/ Brass Compression Limiters - Accepts #8 Screw ; 3M DP270 Epoxy Compound Potted - Shore-83D Hardness

FUNCTIONALITY

Vehicle Attitude Monitoring Features:

Includes Vehicle Kinematic Model and Kalman Filtering for Real-Time Attitude Estimates

- Uses CAN Parametrics, MEMS Sensor Data and Vehicle Frame Dimensioning
- Gyroscope + Accelerometer Data Fusion via Advanced Extended Kalman Filtering
- Performs Compensation for Vehicle Frame Longitudinal and Lateral Accelerations
- Unique Gyroscope Precession Compensation supports Vehicle Maneuvers on Inclined Surfaces

Supports Arbitrary VIM Mounting Location and Rotation when affixed to Vehicle Frame

- Integrated User-Interactive Calibration Functions simplify formulations of:
 - VIM Mounting Rotation Matrix using Yaw, Pitch and Roll
 - Vehicle Drive Wheel Speeds Difference Correction Factor

Vibration Monitoring Features:

3 Axis Selectable Sensitivity / Bandwidth Vibration Monitoring Device w/ J1939 Interface

- Selectable AC / DC Coupling with Full Scale Vibration Ranges of:
 - ◆ $\pm 2\text{G}$ max : 10mG min
 - ◆ $\pm 6\text{G}$ max : 30mG min
- 32dB Typ Instant Dynamic Range with Configurable Bandwidth / Resolution of:

BW (Hz)	Res (Hz)	BW (Hz)	Res (Hz)
60	0.15625	600	1.25
140	0.3125	1200	2.5
300	0.625	2000	5

Real-Time Grms Level Monitoring within 3 Configurable Frequency SubBands

- SubBand Frequency Order Tracking to a Configurable J1939 Sync Parameter

Real-Time Spectrum Display w/ Peak Hold and Logarithmic Display Options

- Fast Update Rate across J1939 using P2P MultiPacket Messaging
- FFT Spectral Overlapping at 25ms Frame Rate results in No Missed Data

CONFIGURATION

VIM Configuration and Maintenance using Yashu Device Utility Software:

User Friendly Utility Software to Configure and Maintain VIM while Installed to Target Vehicle

- Perform VIM Non-Volatile Configurations for Operating Mode with Associated Parameters
- Save and Recall VIM Configurations to Host PC

CONFIGURATION (CONTINUED)

VIM Arbitrary Mounting Position

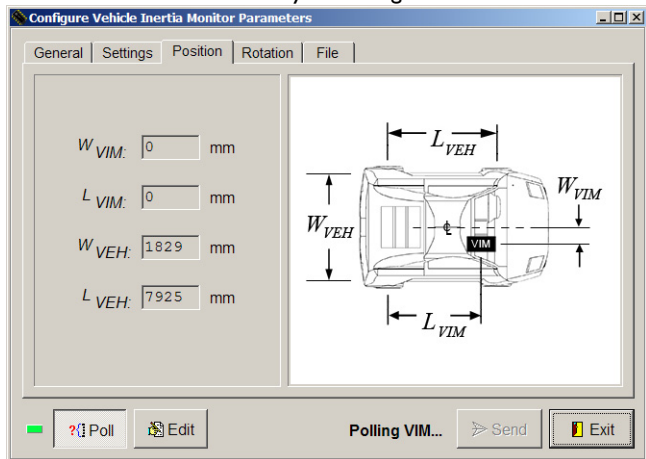

VIM Arbitrary Mounting Rotation w/ AutoCal

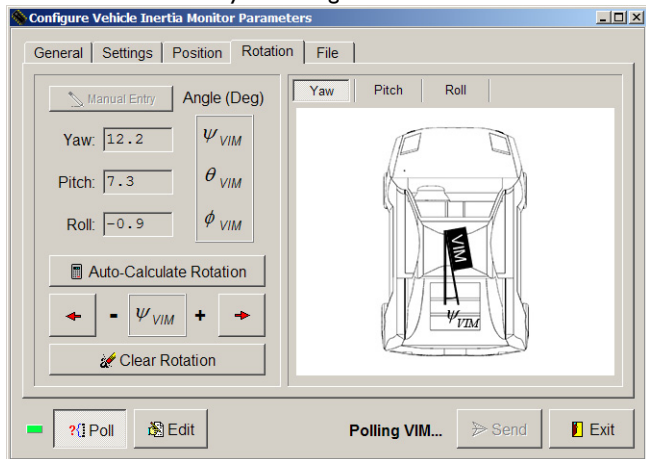

VIM Operating Mode and Settings Vehicle Wheel Speeds L/R Ratio w/ AutoCal

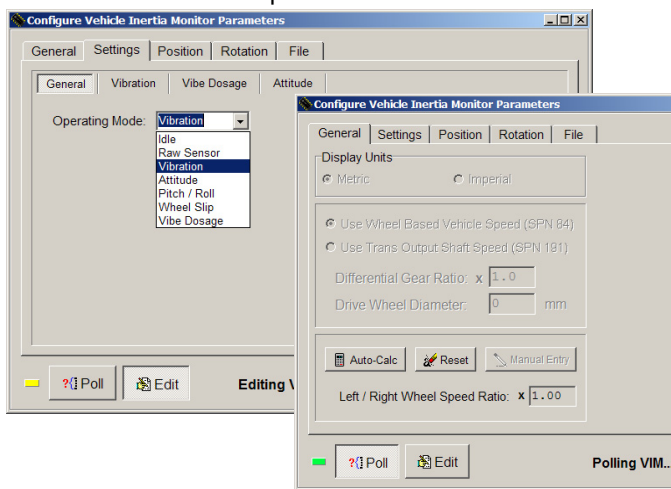

VIM Vibration Mode Parameters

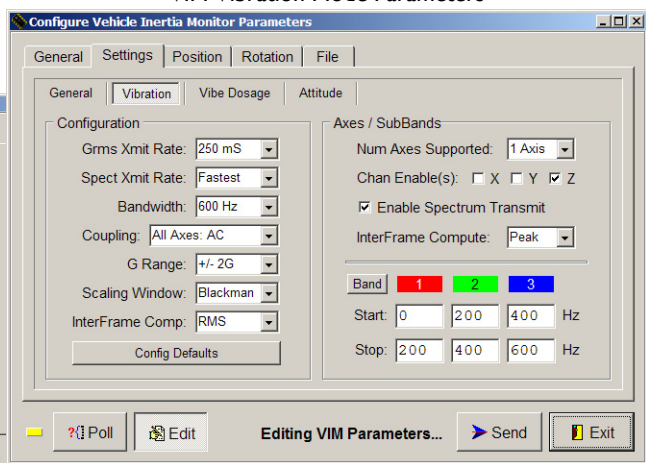

VIM Vibration Dosage Mode Configuration

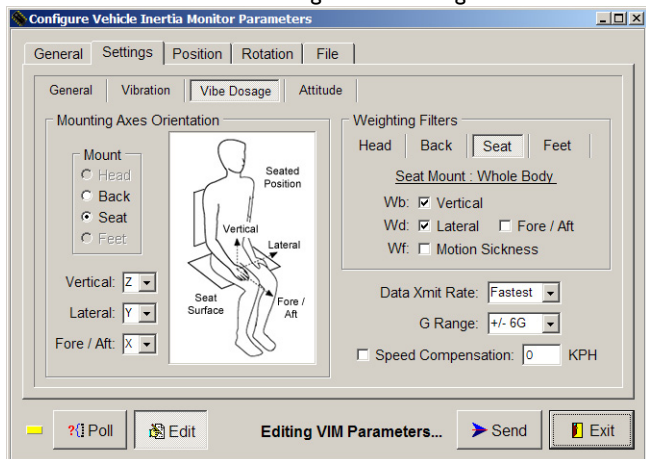

VIM Attitude Mode Parameters

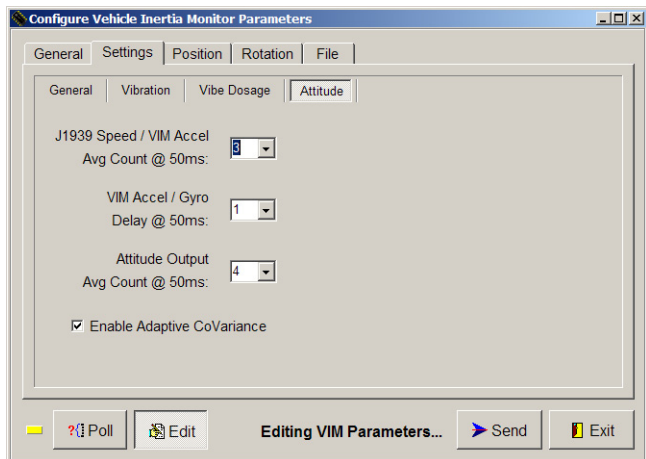

VIM Real-Time Monitoring using Yashu Device Utility Software:

User Friendly Utility Software to Monitor VIM Operation in Real-Time while Installed to Target Vehicle

- Perform VIM Volatile Configurations for Operating Mode with Associated Parameters for Instant Display
- Monitors Raw MEMS Data, Vehicle Attitude, Vibration Grms Levels and Frequency Spectrum in Real-Time
- Save and Recall Logged VIM Data in Standard .CSV Format with User Friendly Descriptive Text Fields

Real-Time Raw MEMS Data Display

- Fast 100ms Update Rate on J1939
- Easily Viewable Traces for Raw MEMS Accelerometer and Gyroscope Data
- Selectable Accel / Gyro Trace Display
- Selectable Discrete Sample Display

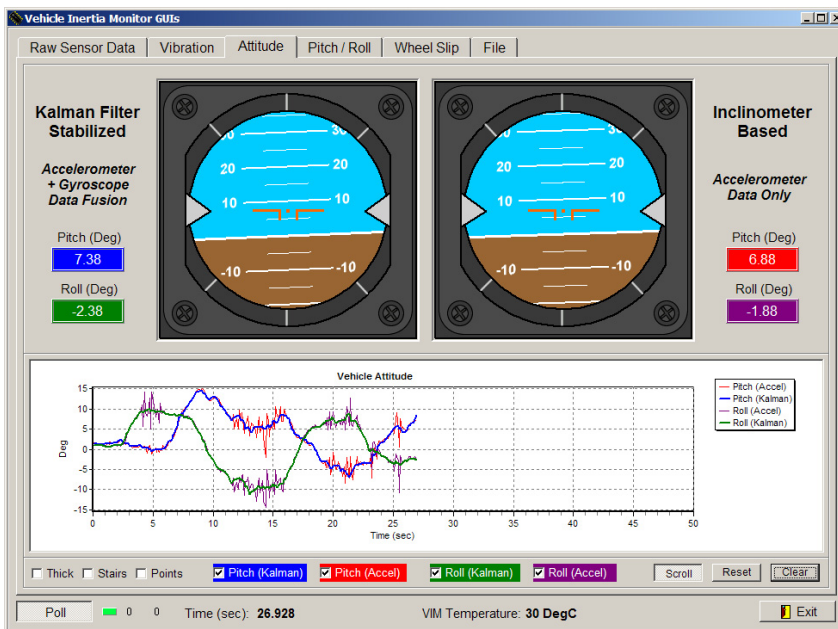
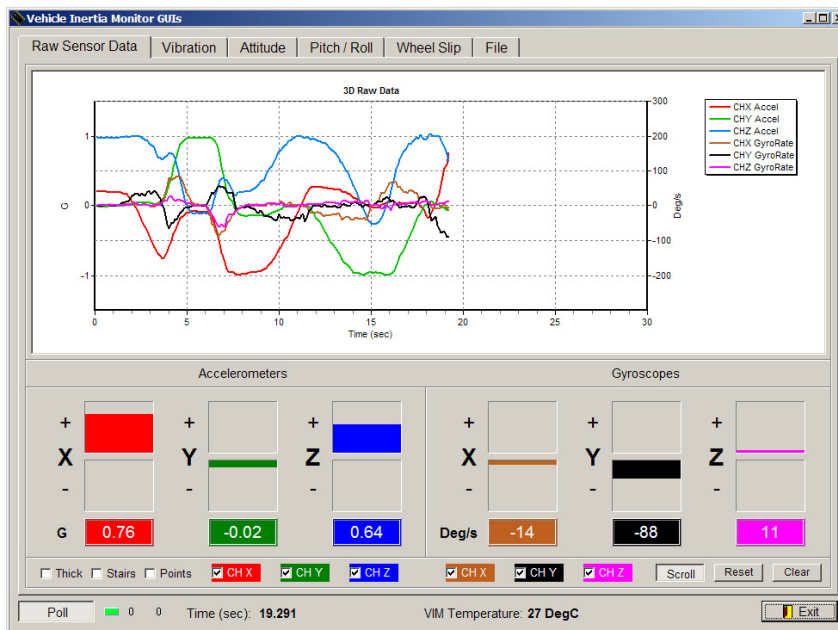

Real-Time Vehicle Attitude Display

- Fast 100ms Update Rate on J1939
- Easily Viewable Artificial Horizons for Kalman Filtered and Accelerometer Only Pitch / Roll Estimates
- Selectable Pitch / Roll Trace Display
- Selectable Discrete Sample Display

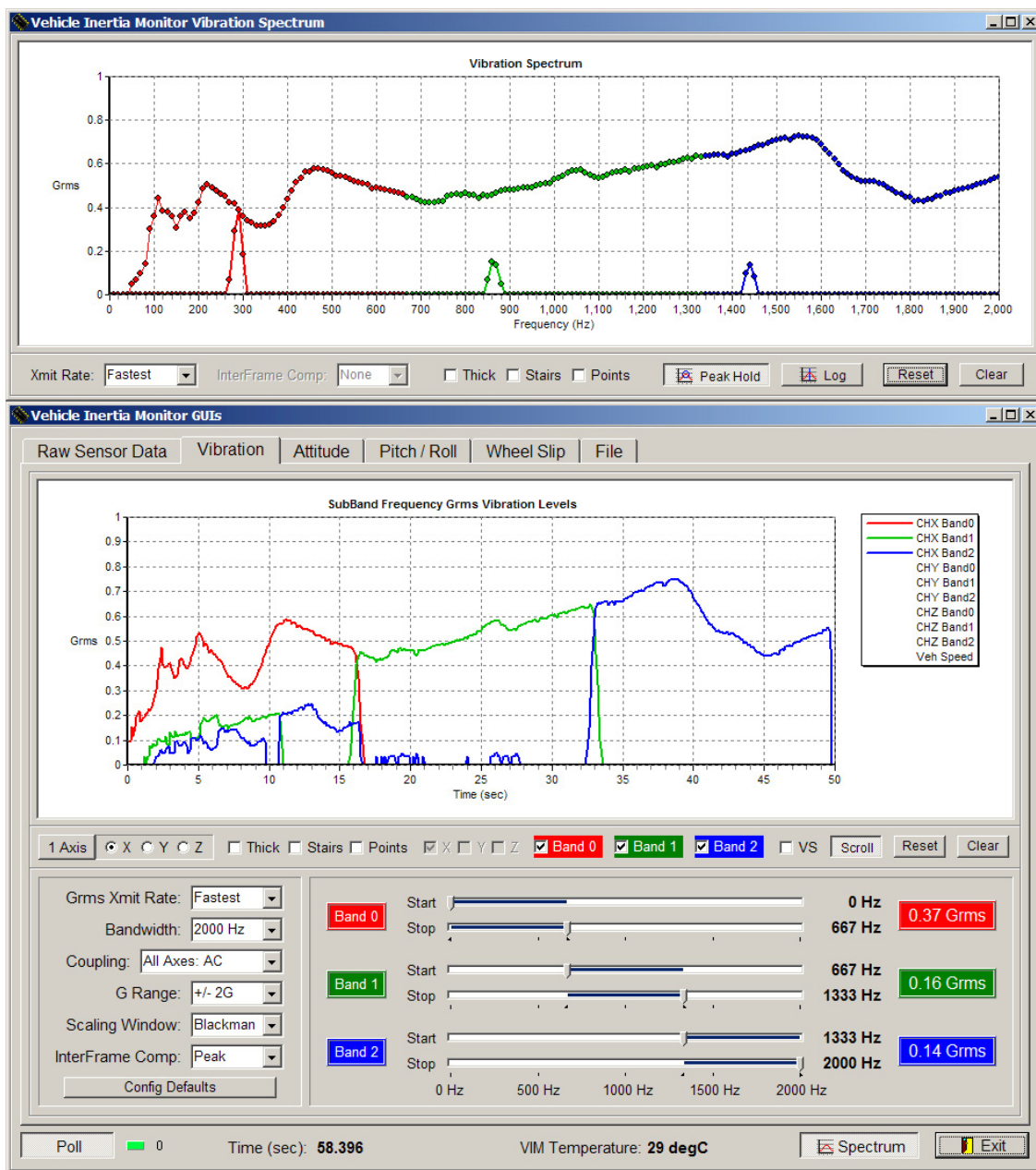

Real-Time Monitoring and Configuration of Vibration Mode Parameters

- Configurable J1939 Transmit Rate and Bandwidth
- Per Axis AC / DC Coupling Capability
- Selectable G-Range Sensitivity
- FFT Scaling Window Selection
 - ◆ None ◆ Hamming ◆ Hanning
 - ◆ Blackman ◆ Bartlett
- InterFrame Computation configures VIM Frame Processing between J1939 PGN Transmissions
 - ◆ None ◆ Peak ◆ Mean ◆ RMS

Real-Time Spectrum Analyzer Support

- Fast 650ms Update Rate across J1939
- Peak Hold and Log Display Options
- Selectable Discrete Sample Display
- FFT Spectral Overlapping at 25ms Frame Rate results in No Missed Data